

Owner's Manual



40" PLUG AERATOR

Model No. 486.24326



DO NOT RETURN TO STORE
For Missing Parts or Assembly
Questions Call 1-866-576-8388

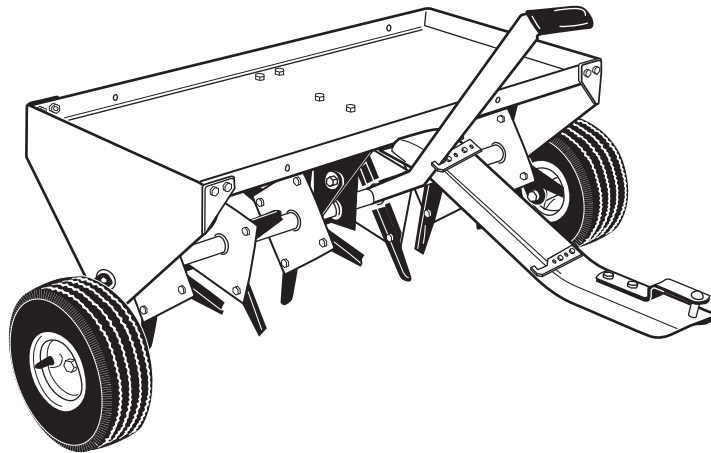

CAUTION:

Before using this product, read this manual and follow all Safety Rules and Operating Instructions.

- Safety
- Assembly
- Operation
- Maintenance
- Parts

Sears, Roebuck and Co., Hoffman Estates, IL 60179 U.S.A.
www.sears.com/craftsman

PRINTED IN U.S.A.

FORM NO. 40016 (REV. 05/15/08)

TABLE OF CONTENTS

SAFETY RULES.....	2	STORAGE	10
FULL SIZE HARDWARE CHART	3	REPAIR PARTS ILLUSTRATION.....	12
CARTON CONTENTS.....	4	REPAIR PARTS LIST.....	13
ASSEMBLY.....	4	PARTS ORDERING/SERVICE	Back Cover
OPERATION.....	8		
MAINTENANCE	10		

WARRANTY

ONE YEAR FULL WARRANTY

When operated and maintained according to the instructions supplied with it, if this Plug Aerator fails due to a defect in material or workmanship within one year from the date of purchase, call 1-800-4-MY-HOME® to arrange for free repair (or replacement if repair proves impossible).

If this product is used for commercial or rental purposes, this warranty applies for only 90 days from the date of purchase.

This warranty gives you specific legal rights, and you may also have other rights which vary from state to state.

Sears, Roebuck and Co., D817WA, Hoffman Estates, IL 60179

<p>The model number and serial numbers will be found on a decal attached to the aerator.</p> <p>You should record both the serial number and the date of purchase and keep in a safe place for future reference.</p>	<table style="width: 100%; border: none;"> <tr> <td style="width: 60%;">MODEL NUMBER:</td> <td style="width: 40%;">486.24326</td> </tr> <tr> <td>SERIAL NUMBER:</td> <td>_____</td> </tr> <tr> <td>DATE OF PURCHASE:</td> <td>_____</td> </tr> </table>	MODEL NUMBER:	486.24326	SERIAL NUMBER:	_____	DATE OF PURCHASE:	_____
MODEL NUMBER:	486.24326						
SERIAL NUMBER:	_____						
DATE OF PURCHASE:	_____						



SAFETY



Any power equipment can cause injury if operated improperly or if the user does not understand how to operate the equipment. Exercise caution at all times when using power equipment.

- Read this owners manual carefully for operating and service instructions before attempting to assemble or operate this equipment. Be thoroughly familiar with the proper use of this equipment.
- Read the vehicle owners manual and vehicle safety rules, and know how to operate the vehicle before using this equipment.
- Never allow children to operate the tractor or plug aerator attachment, and do not allow adults to operate without proper instructions.
- This aerator attachment has sharp knife points. Always handle with care and wear substantial foot wear when operating this aerator.
- Do not allow anyone to ride or sit on plug aerator attachment frame or on towing vehicle.
- Keep the area of operation clear of all persons, particularly small children, and also pets.
- Always begin with the transmission in first (low) gear and engine at low speed, and gradually increase speed as conditions permit.
- The vehicle braking and stability may be affected with the attachment of this equipment. Be aware of changing conditions on slopes. Refer to safety rules in the vehicle owner's manual concerning safe operation on slopes. **STAY OFF OF STEEP SLOPES.**
- Always operate up and down a slope, never across the face of a slope
- This equipment should be operated at reduced speed on rough terrain, along creeks and ditches and on hillsides, to prevent tipping and loss of control. Do not drive too close to a creek or a ditch.
- Do not tow this equipment on a highway or any other public thoroughfare.
- Follow the maintenance instructions as outlined in this owners manual.



Look for this symbol to point out important safety precautions. It means — **Attention!! Become alert!! Your safety is involved.**

HARDWARE PACKAGE CONTENTS

SHOWN FULL SIZE

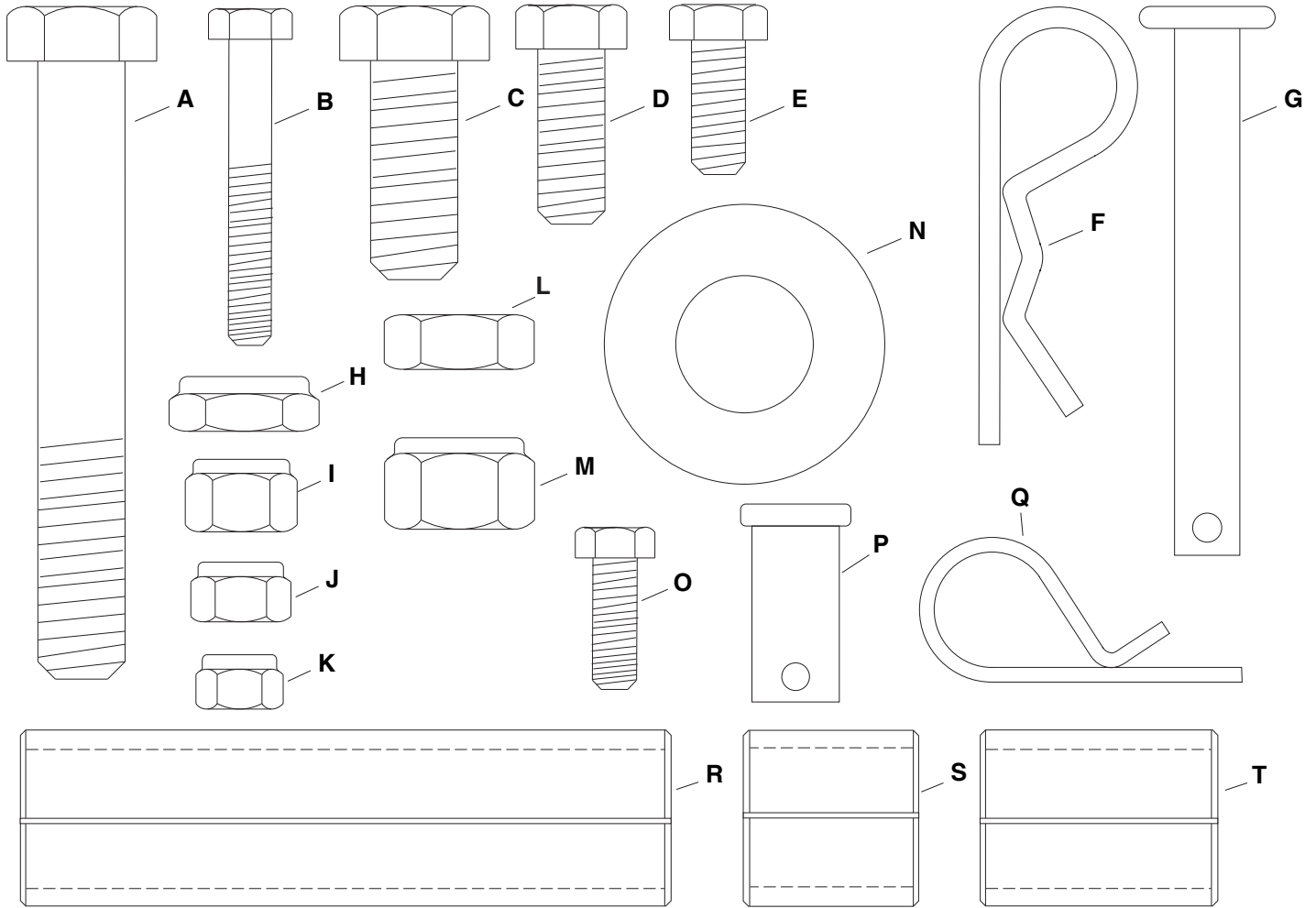

NOT SHOWN FULL SIZE

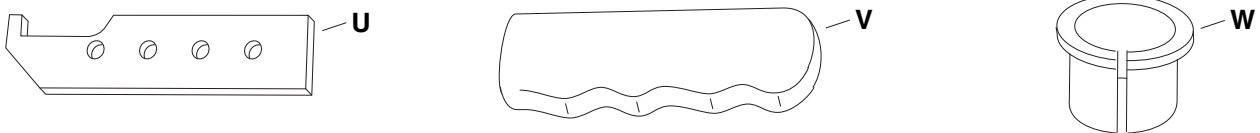

HARDWARE PACKAGE CONTENTS

Key	Qty.	Description	Key	Qty.	Description
A	2	Hex Bolt, 1/2" x 3-1/2" Lg.	M	1	Nylock Nut, 1/2"
B	4	Hex Bolt, 1/4" x 1-3/4" Lg.	N	4	Flat Washer, 3/4"
C	1	Hex Bolt, 1/2" x 1-1/4" Lg.	O	4	Hex Bolt, 1/4" x 3/4"
D	8	Hex Bolt, 3/8" x 1" Lg.	P	1	Clevis Pin
E	8	Hex Bolt, 5/16" x 3/4" Lg.	Q	1	Hair Cotter Pin, Small
F	1	Hair Cotter Pin, Large	R	1	Spacer Tube, 3.70" Long
G	1	Hitch Pin	S	1	Spacer Tube, 1" Long
H	2	Nylock Jam Nut, 1/2"	T	4	Spacer Tube, 1.33" Long
I	8	Nylock Nut, 3/8"	U	2	Stop Bracket
J	8	Nylock Nut, 5/16"	V	1	Handle Grip
K	8	Nylock Nut, 1/4"	W	8	Split Plastic Bearing
L	2	Jam Nut, 1/2"			

ASSEMBLY

CARTON CONTENTS

- | | | |
|-----------------------|------------------------|---------------------------------|
| 1. Tray | 5. Tongue | 9. Single Spool Assemblies (2) |
| 2. Wheel Brackets (2) | 6. End Plates (2) | 10. Shaft |
| 3. Middle Brace | 7. Lift Handle | 11. Double Spool Assemblies (2) |
| 4. Hitch Bracket | 8. Lift Lever Assembly | 12. Wheels (2) |

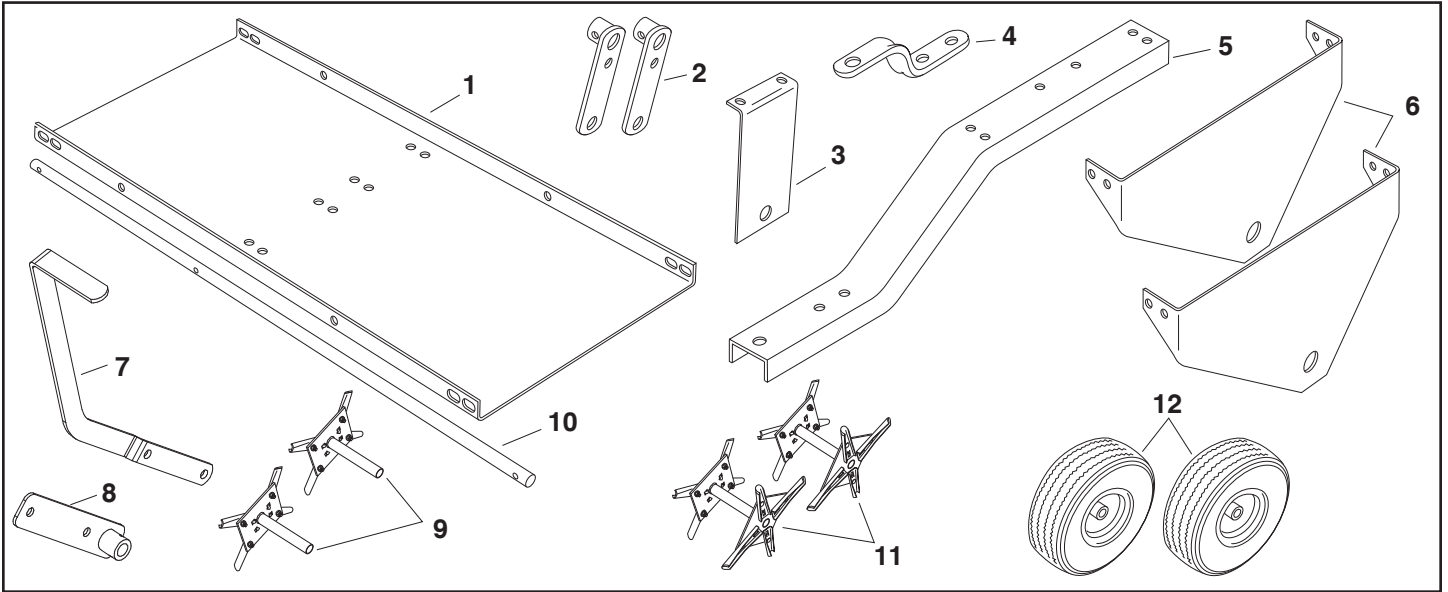

TOOLS REQUIRED FOR ASSEMBLY

- (2) 7/16" wrenches
- (2) 1/2" wrenches
- (2) 9/16" wrenches
- (2) 3/4" wrenches or adjustable wrenches

- Attach the lift lever assembly to the two holes in the middle of the shaft using two 1/4" x 1-3/4" hex bolts (B) and a 1/4" nylock nuts (K). **Tighten.** See figure 1.

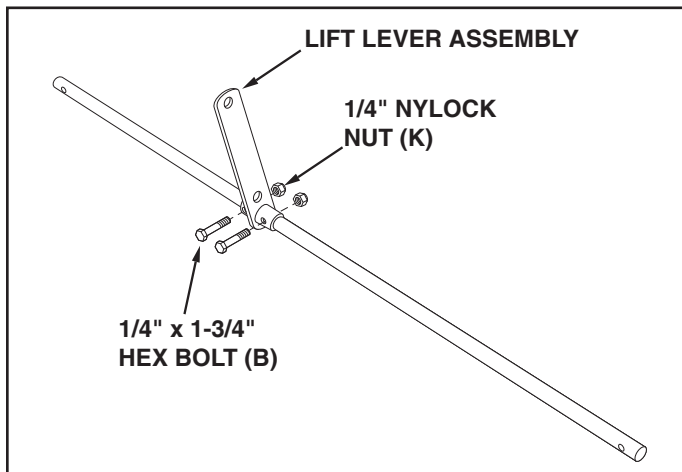

FIGURE 1



CAUTION: Points of aerator knives are sharp! Exercise caution at all times while assembling and using the aerator.

- Push split plastic bearings (Y) into both ends of all single and double spool assemblies. See figure 2.

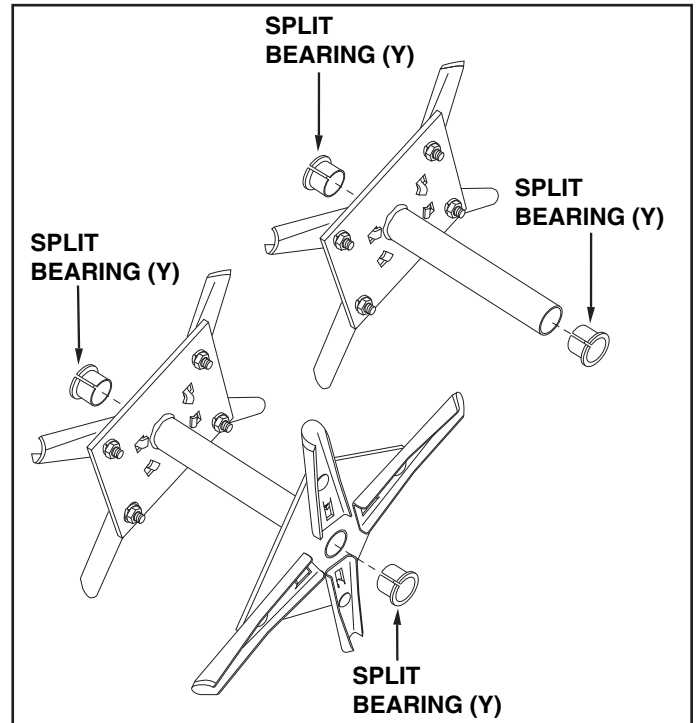

FIGURE 2

- Identify the short end of the shaft. Assemble a 1" long spacer (S), a single spool assembly, a 1.33" long spacer (T), a double spool assembly, another 1.33" long spacer (T) and a 3/4" flat washer (N) onto the **short end** of the shaft. See figure 3.

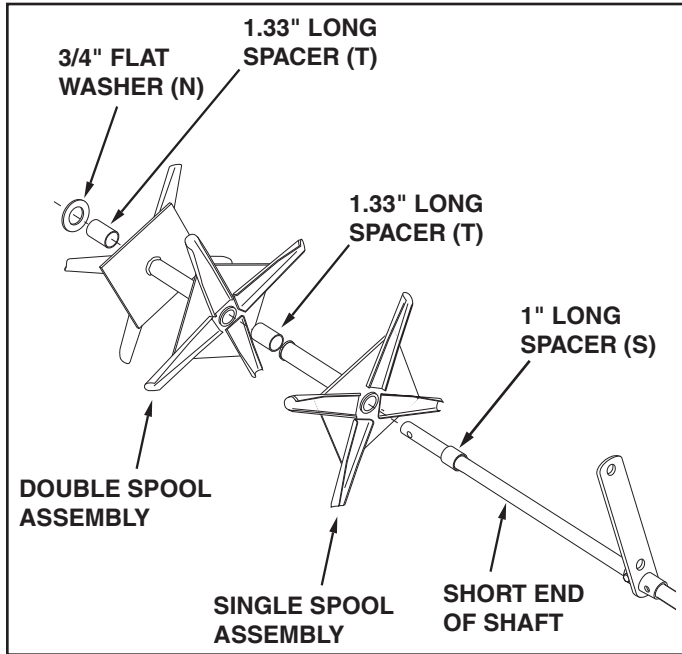

FIGURE 3

- Assemble the middle brace onto the **long end** of the shaft with the bent end of the brace facing the lift lever. Next assemble a 3.70" long spacer (R), a single spool assembly, a 1.33" long spacer (T), a double spool assembly, a 1.33" long spacer (T) and a 3/4" flat washer (N) onto the **long end** of the shaft. See figure 4.

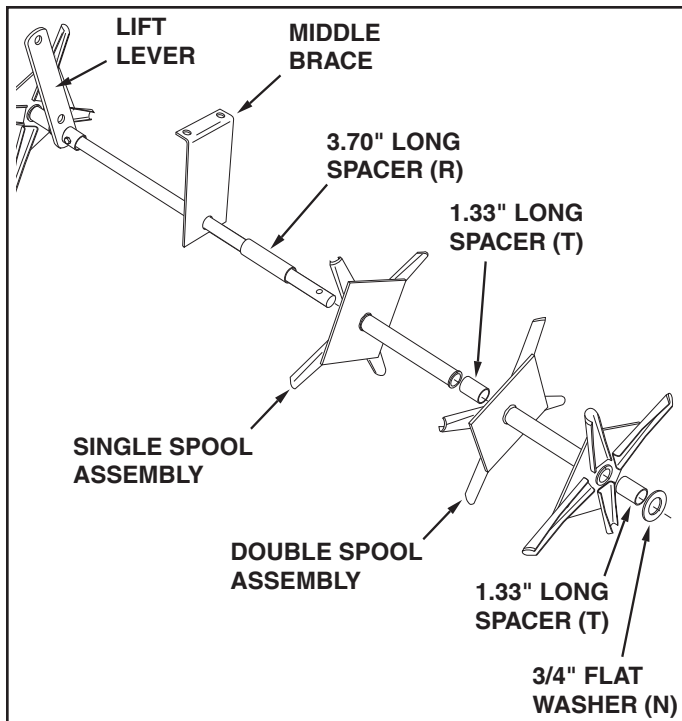

FIGURE 4

REAR VIEW

- Assemble the end plates to the ends of the tray using four 5/16" x 3/4" hex bolts (E) and four 5/16" nylock nuts (J) for each end plate. **Do not tighten until final step.** See figure 5.

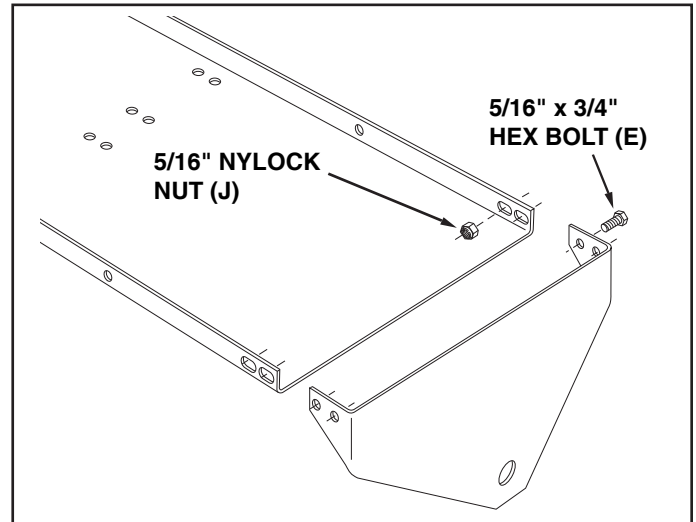

FIGURE 5

- Assemble the tongue to the tray using four 3/8" x 1" hex bolts (D) and 3/8" nylock nuts (I) as shown in figure 6. **Tighten.**
- Assemble the two stop brackets (U) to the tongue using four 1/4" x 3/4" hex bolts (O) and 1/4" nylock nuts (K). Position the bottom bracket as far to the right side as possible. Position the top bracket as far to the left side as possible. **Tighten.** See figure 6.

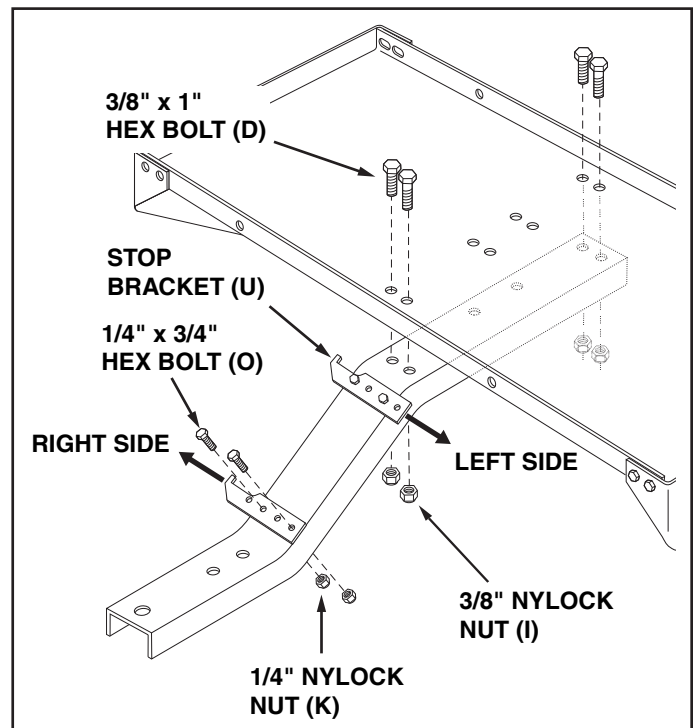

FIGURE 6

- Assemble the hitch bracket to the tongue using two 3/8" x 1" hex bolts (D), and two 3/8" nylock nuts (I). **Tighten.** See figure 7.
- Assemble the hitch pin (G) through the hitch bracket and the tongue. Secure the hitch pin with the large hairpin cotter (F). See figure 7.

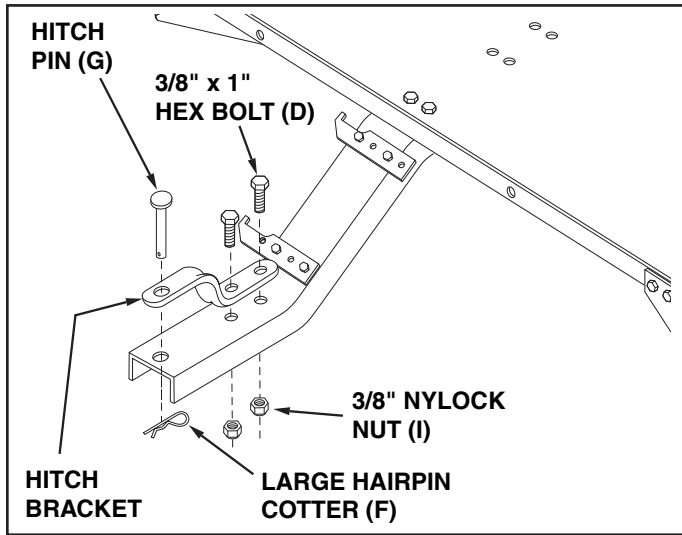

FIGURE 7

- Turn the tray upside down. Standing behind the tray, place the **long end** of the shaft through the end plate on your right as shown in figure 8. Place the other end of the shaft through the end plate on your left. Make sure the bent end of the middle brace rests flat inside the tongue.
- Assemble a 3/4" flat washer (N) and a wheel bracket onto each end of the shaft. Turn each wheel bracket to point in the opposite direction from the lift lever. Secure each wheel bracket with a 1/4" x 1-3/4" hex bolt (B) and 1/4" nylock nut (K). **Tighten.** See figure 8.

NOTE: If there is not enough room on the shaft for the wheel bracket, leave off the 3/4" flat washer(s) from that end of the shaft.

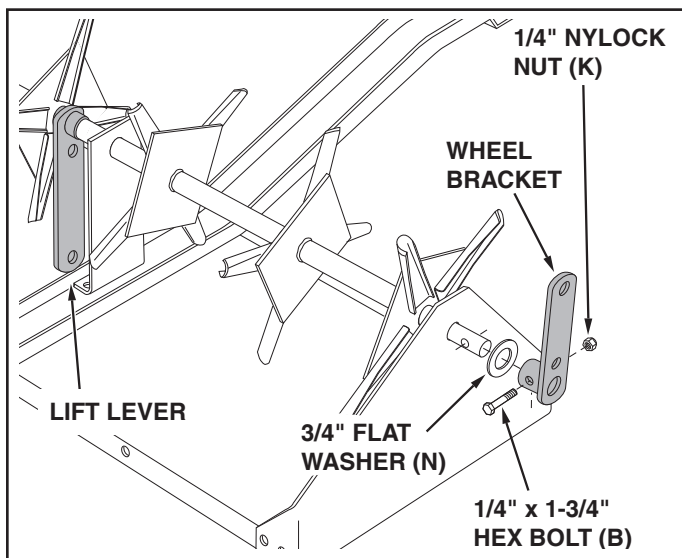

FIGURE 8

UPSIDE DOWN VIEW

- Assemble a wheel to a wheel bracket as shown in figure 9. Use a 1/2" x 3-1/2" hex bolt (A), one 1/2" hex jam nut (L), and one 1/2" nylock jam nut (H). Adjust the nuts so that the wheel is held securely with minimum end play but will spin freely. Repeat on other side. See figure 9.

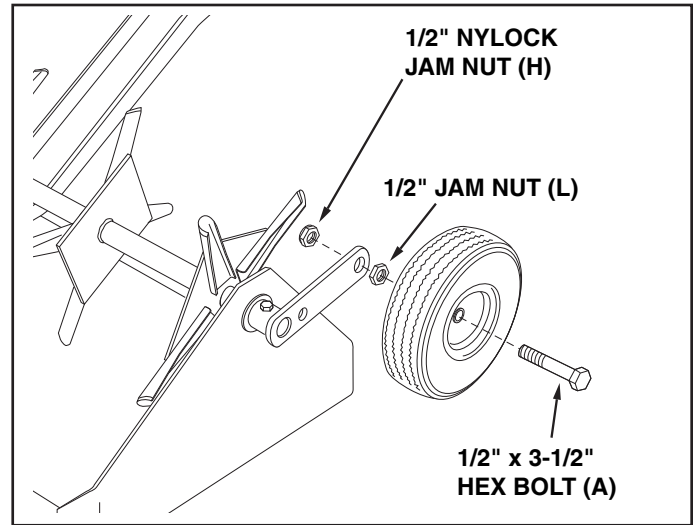

FIGURE 9

UPSIDE DOWN VIEW

- Tip the aerator onto the back edge of the tray. Fasten the middle brace to the bottom of the tongue using two 3/8" x 1" hex bolts (D) and 3/8" nylock nuts (I). **Do not tighten until final step.** See figure 10.

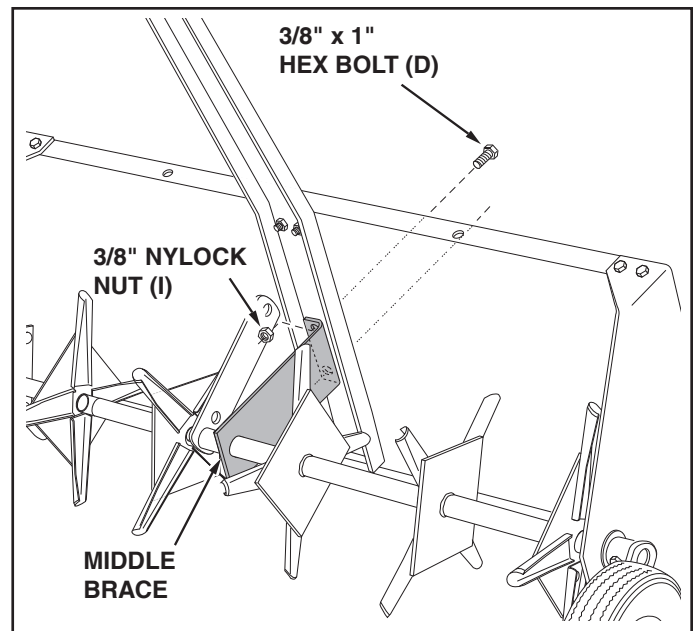

FIGURE 10

- Turn the lift handle as shown in figure 11 and attach it to the side of the lift lever that is indicated. Use a 1/2" x 1-1/4" hex bolt (C) and 1/2" nylock nut (M) in the bottom hole and the clevis pin and small hairpin cotter in the top hole. **Tighten** the bolt and nut. See figure 11.
- Push the grip (V) onto the lift handle. See figure 11.

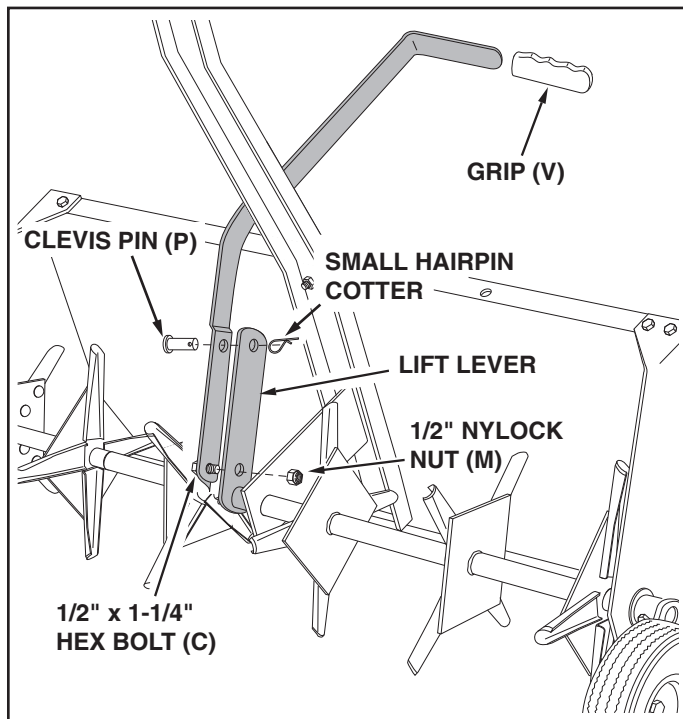

FIGURE 11

- Perform the following steps in sequence to tighten the bolts and nuts that remain loose. Refer to figure 12.
 - a. Turn the aerator upright, then lock the lift handle into the transport position.
 - b. **Tighten** the eight bolts at the corners of the tray.
 - c. **Tighten** the two bolts which fasten the middle brace to the bottom of the tray.

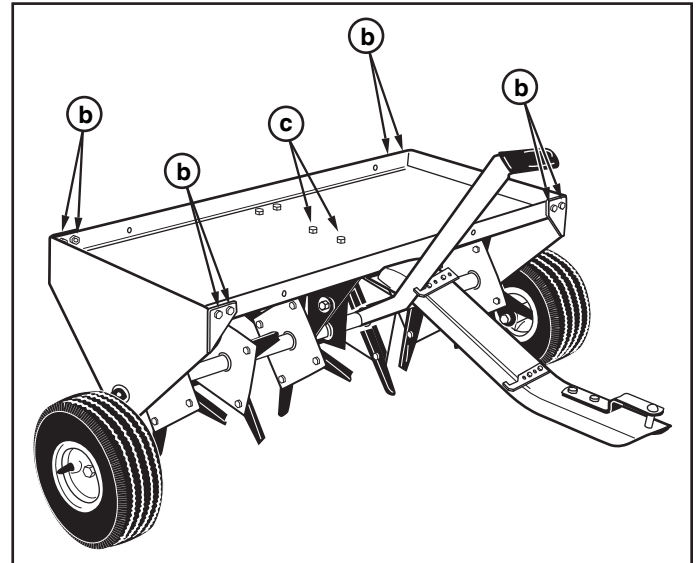

FIGURE 12

OPERATION

KNOW YOUR PLUG AERATOR

Read this owner's manual and safety rules before operating your plug aerator.

Compare the illustration below with your aerator to familiarize yourself with the various controls and their locations.

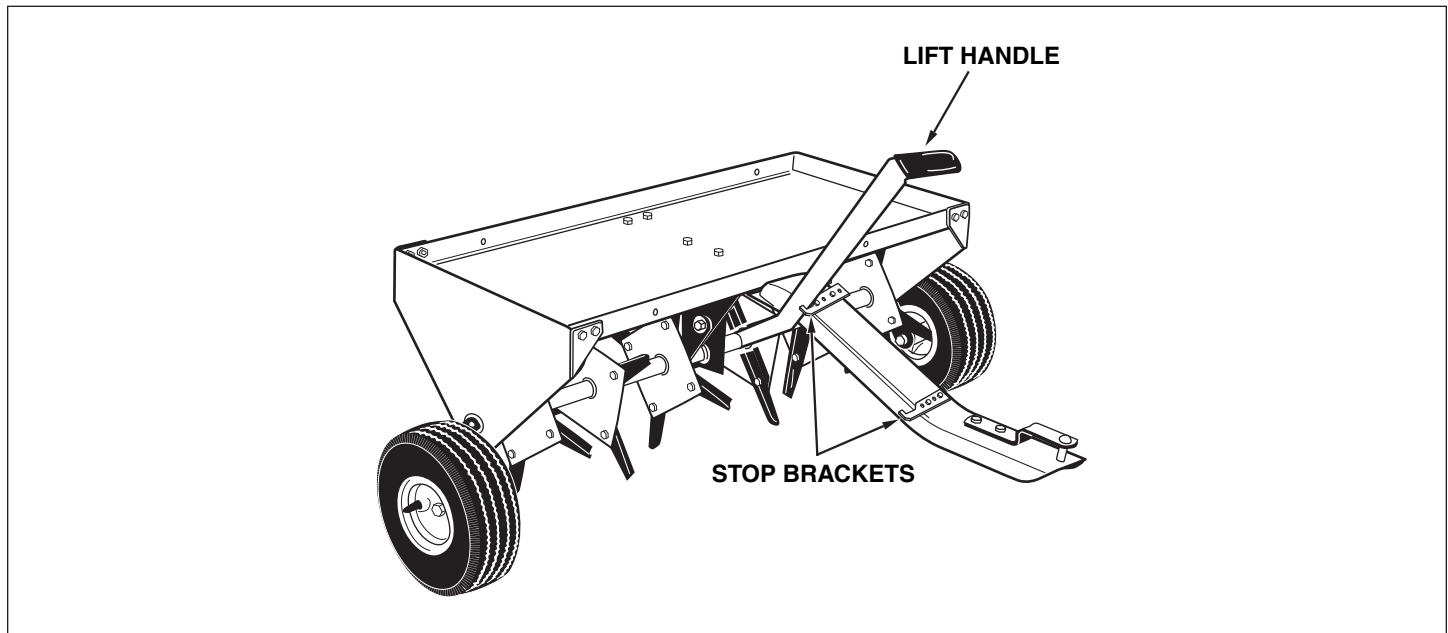

LIFT HANDLE Raises the aerator to the transport position and lowers it to the operating position.

STOP BRACKETS Locks the lift handle in the transport position (upper bracket) or operating position (lower bracket).

BEFORE STARTING

- Mow the lawn and remove loose clippings prior to use of the aerator.
- If the soil is extremely hard and dry, it is recommended that it be sprinkled or watered down for one or two hours prior to aerating.



CAUTION: Points of aerator knives are sharp! Exercise caution at all times while using the aerator.



CAUTION: Vehicle braking and stability may be affected by the addition of an accessory or attachment. Be aware of changing conditions on slopes.

HOW TO USE YOUR PLUG AERATOR

Aerating means pulling small soil plugs, ranging up to three inches in length, from the soil to create small reservoirs that will bring oxygen, fertilizer and water down into the roots. For best aerator performance, the following lawn preparations and operating procedures are recommended.

- Start tractor engine with controls in neutral and place throttle at slow engine speed.
- Engage shift lever at lowest possible forward speed and lower aerator, allowing plugger points to enter the ground. Increase speed as conditions permit.
- Aerate in the straightest line possible, making overlapping passes to increase the plugger point pattern.
- **Avoid extremely sharp turns** with plugger points engaged in ground to prevent damage to lawn.
- **DO NOT** cross over walks or drives without first raising the aerator to the transport position.
- On sloped lawns, always aerate in an up and down direction. **DO NOT** attempt to follow the contour of the ground.

- **DO NOT** attempt to aerate if ground is too wet, or muddy.
- Due to possible small rocks and gravel which can be present in aerated soil plugs, it is recommended that the plugs be raked; otherwise damage to the lawn mower blades may arise, especially when reel type mowers are used.
- To increase the depth of plugger point penetration, up to 140 lbs. of weight, such as bags of sand or (4) concrete blocks, may be added to the tray. The weight can be secured to the tray with ties or straps fastened to the front and rear of the tray. Fasten so that the ties or straps cannot become entangled on rotating parts. See figure 13.

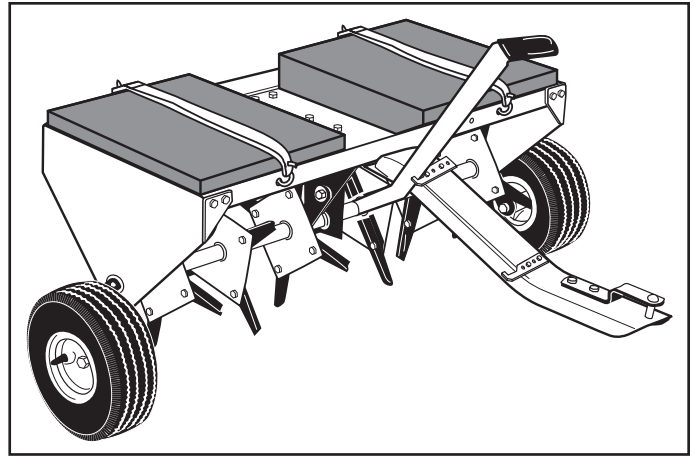

FIGURE 13



CAUTION: To prevent injury, dismount from the tractor to raise or lower aerator containing added weight.

MAINTENANCE

CUSTOMER RESPONSIBILITIES

- Read and follow the maintenance schedule and the maintenance procedures listed in this section.

MAINTENANCE SCHEDULE Fill in dates as you complete regular service.	Service Dates											
	Before each use	After each use	Every season	Before storage								
Check for loose fasteners	X											
Cleaning		X										
Lubrication			X									

CHECK FOR LOOSE FASTENERS

- Before each use make a thorough visual check of the plug aerator for any bolts and nuts which may have loosened. Retighten any loose bolts and nuts.

LUBRICATION

- Lubricate wheels as needed.
- Oil the spool assemblies and shaft as needed.

CLEANING

- Clean dirt off of aerator knives after each use. **BE CAREFUL OF SHARP EDGES WHEN CLEANING.**

SERVICE AND ADJUSTMENTS

- Plugger points can periodically be sharpened with a small grinder to maintain good penetration. Points should be removed to sharpen. Follow original angle and contour of points when grinding.

STORAGE

- Clean the aerator and store in a dry area. Coat exposed metal with light oil to prevent rust.

REPAIR PARTS FOR 40" PLUG AERATOR MODEL 486.24326

REF. NO.	PART NO.	QTY.	DESCRIPTION	REF. NO.	PART NO.	QTY.	DESCRIPTION
1	25853	1	Tray	21	43019	2	Hex Jam Nut, 1/2-13 Thd.
2	24623	1	Middle Brace	22	43009	4	Flat Washer, 3/4"
3	24619	2	End Plate	23	741-0493A	8	Split Bearing, 3/4"
4	25664	1	Lift Handle	24	45151	1	Spacer, 3.70" Long
5	25800	1	Tongue	25	44494	4	Spacer, 1.33" Long
6	25801	1	Shaft	26	712-3083	1	Hex Nylock Nut 1/2"
7	23687	1	Hitch Bracket	27	44500	1	Spacer, 1.00" Long
8	46503	2	Wheel	28	43943	1	Grip
9	63931	2	Wheel Bracket Assembly	29	47623	1	Hitch Pin, 3/8" Flat Head
10	63929	2	Spool Assembly (Double)	30	43343	1	Hair Cotter Pin, 3/32"
11	63930	2	Spool Assembly (Single)	31	24924	24	Knife, Aerator
12	65336	1	Lift Bracket Assembly	32	43080	24	Carriage Bolt, 5/16-18 x 3/4"
13	43001	8	Hex Bolt, 3/8-16 x 1" Long	33	HA21362	8	Hex Nylock Nut 3/8"
14	43055	1	Hairpin, 3/32 x 1.8	34	47189	8	Hex Nylock Nut 1/4"
15	43351	1	Hex Bolt, 1/2-13 x 1-1/4" Long	35	43086	24	Lockwasher 5/16"
16	43182	8	Hex Bolt, 5/16-18 x 3/4" Long	36	43012	4	Hex Bolt, 1/4-20 x 3/4" Long
17	47810	32	Hex Nylock Nut 5/16"	37	25665	2	Lift Stop Bracket
18	48115	2	Hex Nylock Jam Nut 1/2"	38	44056	1	Clevis Pin
19	1509-69	4	Hex Bolt, 1/4-20 x 1-3/4" Long		40016	1	Owners Manual
20	46526	2	Hex Bolt, 1/2-13 x 3-1/2" Long				

Get it fixed, at your home or ours!

Your Home

For repair – **in your home** – of **all** major brand appliances, lawn and garden equipment, or heating and cooling systems, **no matter who made it, no matter who sold it!**

For the replacement parts, accessories and owner's manuals that you need to do-it-yourself.

For Sears professional installation of home appliances and items like garage door openers and water heaters.

1-800-4-MY-HOME® (1-800-469-4663)

Call anytime, day or night (U.S.A. and Canada)

www.sears.com www.sears.ca

For expert home solutions advice: www.managemyhome.com

Our Home

For repair of carry-in items like vacuums, lawn equipment, and electronics, call or go on-line for the location of your nearest

Sears Parts & Repair Service Center

1-800-488-1222 (U.S.A.) 1-800-469-4663 (Canada)

Call anytime, day or night

www.sears.com www.sears.ca

To purchase a protection agreement on a product serviced by Sears:

1-800-827-6655 (U.S.A.) 1-800-361-6665 (Canada)

Para pedir servicio de reparación a domicilio, y para ordenar piezas:

1-888-SU-HOGAR®

(1-888-784-6427)

Au Canada pour service en français:

1-800-LE-FOYER^{MC}

(1-800-533-6937)

www.sears.ca

